

BioProTT™ FlowSU Sensor

SINGLE-USE, IN-LINE SENSOR



FEATURES

- Single-use, in-line
- Available in several sizes
- All sizes compatible with the same evaluation device
- Gamma-sterilizable once with up to 50 kGy

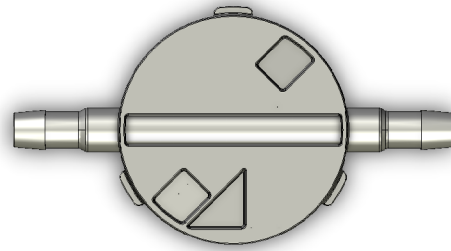

TECHNICAL SPECIFICATIONS

Dimensions (H x W x D) and Weight	90 x 175 x 36.5 mm; ±2 mm; 75 g
Available Sizes (i.e. inner diameter)	1/4" (will be available in the future) 3/8" (will be available in the future) 1/2" 3/4" (will be available in the future) 1" (will be available in the future)
Housing Material	Lexan Grade HPH4404
Degree of Pollution	2
Classification of Wetted Parts	USP Class VI, free of animal derived components and TSE/BSE
Packaging and Cleanroom Conditions	packaged under ISO Class 7 cleanroom conditions compliant to USP 85, 87, 88, 661, 788, and DIN 11737-1: 2021
Connection to Evaluation Device	male USB-C connector
Mounting	toolless, innovative locking mechanism
Compatibility	multi-use BioProTT™ FlowSU System
IP Class	IP 20 in unmated and/or dismounted condition IP 65 (=UL 50E Type 2) in mated and/or mounted condition
Expected Shelf Life	24 months after gamma sterilization
Duration of Use	60 days
Medium Temperature	4° C to 60° C

SENSOR SIZES AND MEASUREMENT RANGE

Sensor Size	Qmin [l/min]	Qmax [l/min]	max. working pressure [bar]**]
1/4"*	1	8	5.1
3/8"*	1.25	15	5.1
1/2"	1.5	20	5.1
3/4"*	4	50	5.1
1"*	6	80	5.1

ACCURACY

Sensor Size	maximum deviation at flow rates below Qmin	accuracy between Qmin and Qmax
1/4"*	20 ml/min	2 %
3/8"*	25 ml/min	2 %
1/2"	30 ml/min	2 %
3/4"*	80 ml/min	2 %
1"*	120 ml/min	2 %

Please note: The specified accuracies were determined under the following conditions:

- medium: distilled water with sodium chloride (salinity between 0.8 ppt and 1.4 ppt) and fully developed flow profile
- straight inlet section: 15 x inner diameter of sensor

Please also note:

- The accuracy is specified within the defined flow measurement range. The flow measurement range is limited by the Qmin and the Qmax.
- The installation position of the BioProTT™ FlowSU System in regard to the positioning of pumps and valves within the circuit impacts the measurement and must be taken into account when it comes to the accuracy of the BioProTT™ FlowSU System.

* Will be available soon.

** In combination with appropriate tubes.

AMBIENT CONDITIONS DURING TRANSPORT, STORAGE, AND OPERATION

Transport and Storage

Atmospheric Pressure	70 kPa to 106 kPa
Temperature Range Transport	-20° C to 55° C (-4° F to 131° F)
Temperature Range Storage	-20° C to 45° C (-4° F to 113° F)
Relative Humidity	10 % to 96 % (non-condensing)

Operation

Atmospheric Pressure	70 kPa to 106 kPa
Operating Altitude	up to 2000 m (6600 feet)
Temperature Range	10° C to 40° C (50° F to 104° F)
Relative Humidity	10 % to 96 % (non-condensing)

TECHNICAL DRAWING

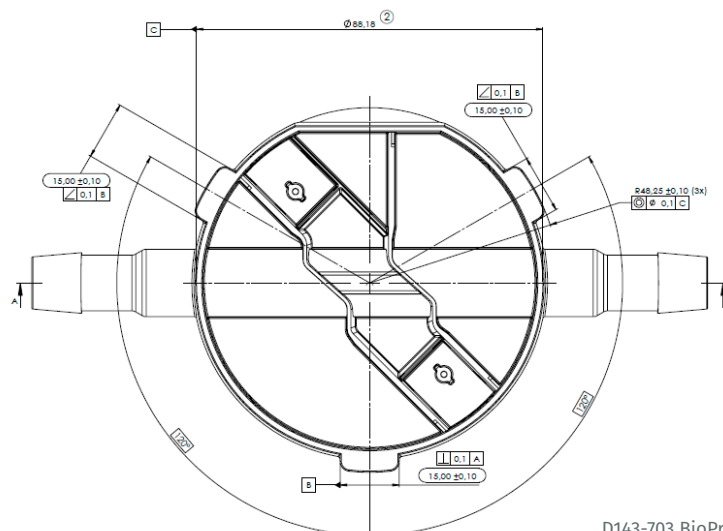

ProcessHQ, Inc.

410 N. Varney Street
 Burbank, CA 91502
 818 861-7641 (voice)
 818 475-1589 (fax)
 info@processHQ.com



PSG Biotech | em-tec GmbH
 Lerchenberg 20
 86923 Finning, Germany
 T +49 8806 9236 0
 em-tec-sales@psgdover.com
psgdover.com/biotech

D143-703 BioProTT™ FlowSU Sensor — Data Sheet — V3.0

© 2023 PSG*, a Dover company
 PSG* reserves the right to modify the information and illustrations contained in this document without prior notice. This is a non-contractual document.